

## E-FOMT

MONITOR ARM ADAPTER  
FOR STEELCASE® FRAMEONE

Model E-FOMT-SLV

E-FOMT Rev A 2/17

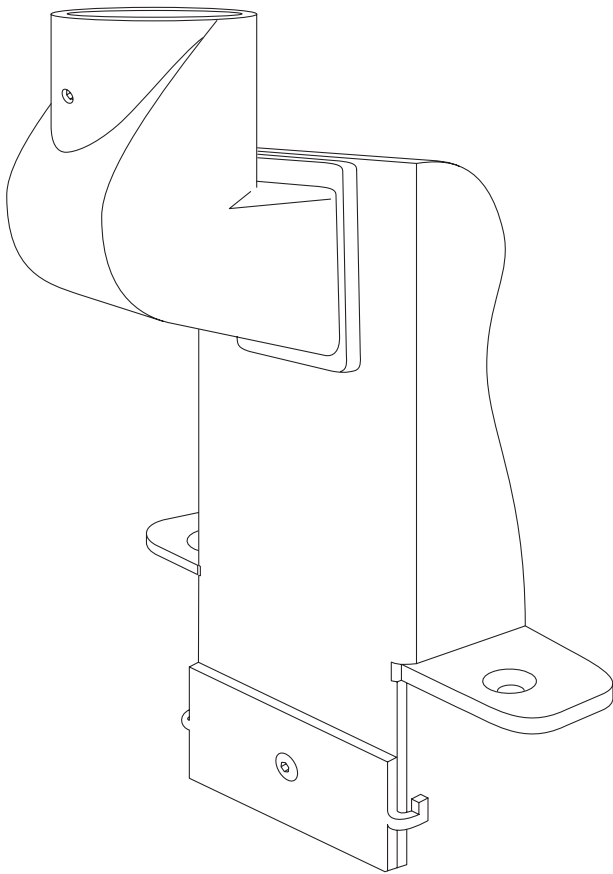





# ASSEMBLY / ADJUSTMENT

## E-FOMT MONITOR ARM ADAPTER

**PLEASE REVIEW** these instructions before beginning the installation. Check that all parts and tools shown below were provided with your order. Contact your supplier if any parts are missing. Do not discard the packaging until satisfied that the product operates to your satisfaction.

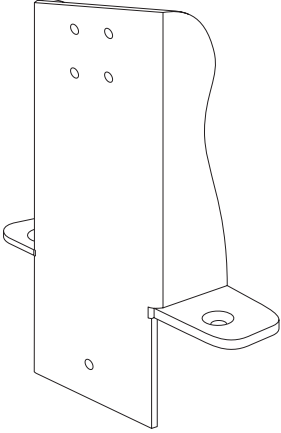
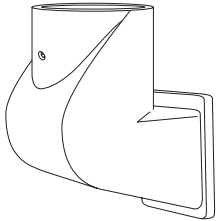
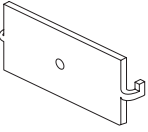
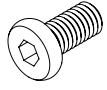
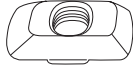
The E-FOMT monitor arm adapter enables attachment of select Edge and Evolve monitor arms to Steelcase® FrameOne benching systems. After the E-FOMT installation is complete, follow the instructions that came with the Edge or Evolve system. The E-FOMT only works with the EDGE single monitor arm or the EVOLVE single, dual, and tripple configurations.

### PARTS PROVIDED

<p>Base (1)</p> 	<p>Knuckle Pole Receptacle with Bushing (1)</p> 	
<p>Base Plate (1)</p> 		
<p>M6 X 12M (2)</p> 	<p>Rectangular Nut 5M (2)</p> 	<p>Knuckle Pole Screw M5 X 10M (4)</p> 
<p>Base Plate Screw M5 X 10M (1)</p> 	<p>Set Screw 4M x 9M (1)</p> 	

**CAUTION:** Hand-tighten screws only. Do **not** use power tools.

### TOOLS REQUIRED

- 2mm, 3mm, 4mm, and 5mm Allen keys

### Clamp Base Assembly to Table

1. Attach the knuckle pole receptacle to the base using the four knuckle pole screws provided.
2. Insert the two flathead socket screws through the left and right side holes of the base. Loosely secure the square head nuts onto the screws.  
**IMPORTANT:** The flat surface of the nuts must be facing up, toward the screw head. If not, they will not lock into the rail.
3. Place the base on top of the table's rear rail. Insert the rectangular head nuts into the rail. Tighten the flathead socket screws with a 4mm Allen key until the nuts lock into the rail.
4. Place the base plate on the lower portion of the base and lock into the lower rail of the FrameOne system. Secure with the base plate screw using a 3mm Allen key.

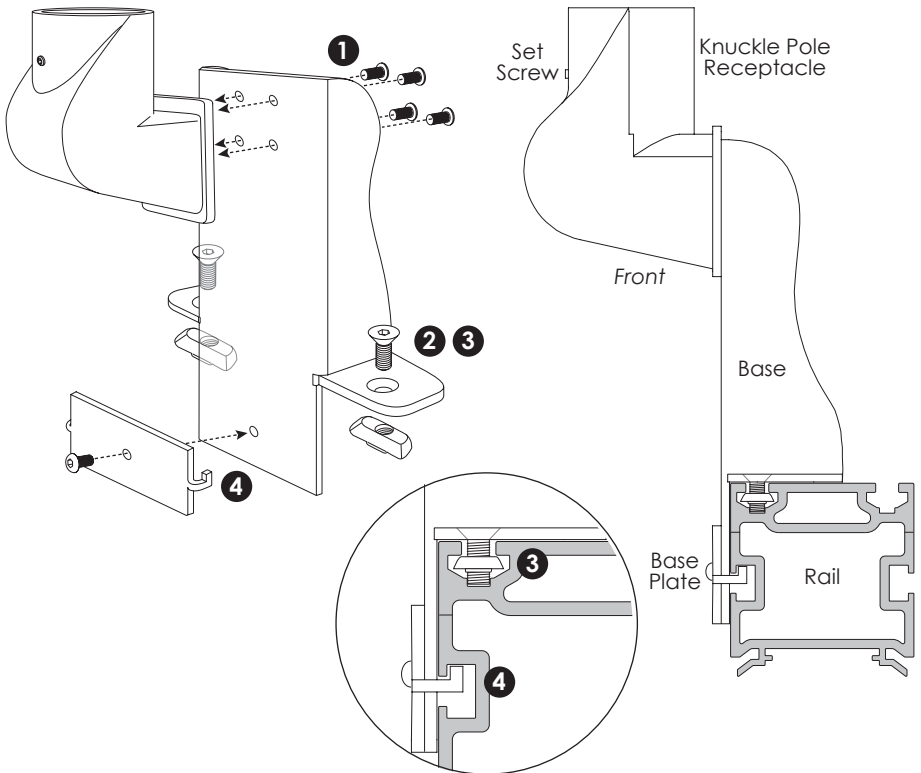

### Proceed with Monitor Arm Assembly

- Install the Evolve pole or Edge monitor arm into the base assembly and secure with the set screw. Proceed according to the instructions that came with the Edge or Evolve system.



800.833.3746 | [esiergo.com](http://esiergo.com)