

CPU Holder

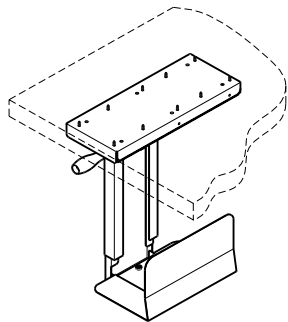

Before starting assembly
Please spend some times to read this assembling
and follow the procedures step by step
assembly guide.
Some panels are viewed differently from the
exploded drawing below. This is for extra clarity.
Do not discard any of the packaging until you
have checked all the parts and the package of
fittings. If you are missing any of the parts,
please contact the store from which you
purchased your products. The staff will do their
best to help you.

Parts Check-List

Code	Component	Qty
01	Top Bracket	1
02	Bottom Bracket	1
03	Holder	1
04	Slider	1
05	Slide Support	1
06	Handle	1

Fitting Check-List

Code	Description	Qty
07	Screw	10
08	Screw	10
09	Spacer	1
10	Washer	1
11	Knob	1
12	Thick Pad	2
13	Round Foam Pad	1set
14	Foam Pad	4

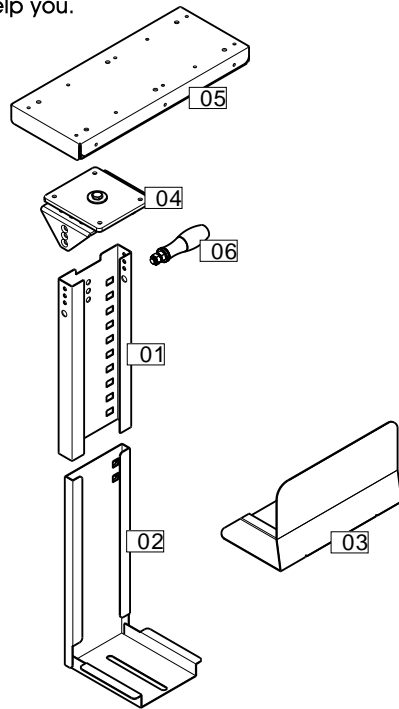

Tools Check-List

Allen Key



Caution:

Regular cleaning with a clean dry cloth is usually sufficient, but for stubborn marks, wipe over gently with a clean damp cloth. Never use strong detergents or abrasive cleaners as these may damage the surface finish of your furniture. There are many small components used in the construction of this unit. These loose items should be kept away from young children while assembling your unit.

Assembly Guide

